



PRODUCT OVERVIEW

LEVEL MEASUREMENT

MAC Sensor Co.,LTD.
Changsha City,Hunan,China
<http://www.macsensor.com>

TEL: +86-731-89975636 / 89975645

L707E Smaller Diameter Submersible Pressure Level Transducer & Transmitter



Characters:

- ☆ Accuracy: $\leq \pm 0.5\%F.S$
- ☆ Wide working temperature scope
- ☆ Advanced digital temperature compensation.
- ☆ Excellent resistance against impact, overload, shock and erosion
- ☆ Highly-efficient lightning protection and strong RFI & EMI resistance
- ☆ High quality piezoresistive sensing element
- ☆ 1.5 times standard overload
- ☆ 3 times burst pressure
- ☆ Diameter 16 mm only

Applications:

- ★ Well level measurement and control
- ★ Borehole measurement
- ★ Automatic detection system
- ★ Groundwater monitoring
- ★ Water supply wells
- ★ Agricultural irrigation wells
- ★ Mining dewatering systems
- ★ Environmental observation wells
- ★ Landfill leachate monitoring
- ★ Construction site dewatering

Profile

L707E is a full sealed submersible level transducer/transmitter. It is made by highly stable and reliable 316L stainless steel pressure sensor and circuit board into the stainless steel housing. Integrated construction and standard signal provide the user easy and convenient application in the local working place. The special cable connects with housing, can be immersed into the media for a long time. It features lightning protection, surge protection, electrostatic protection, polarity protection and over voltage protection. With a new anti-frequency conversion DC pump design added, it allows being used in a wider range of complex working conditions.

L707E has a 16mm diameter compact size, light weight and good stability; it can be used for water or liquid measure and control in various applications.

Specifications

Model	L707E				
Parameter					
Measuring range	0-20m...200mH ₂ O, others on request 0-50m for the short type/50-200m for the long type				
Overload	150% F.S				
Burst pressure	300% F.S				
Accuracy	≤±0.5%F.S @25°C				
Long-term stability	Standard: 0.1%F.S±0.05%				
Working Temp.	-30°C~70°C				
Storage Temp.	-40°C~85°C				
Temperature compensation	0°C~50°C(Full temp 1%F.S. accuracy)				
Medium compatible	Compatible with 316L Stainless Steel				
Electrical wire	2 Wire	3 Wire			4Wire
Output	4~20 mA	0-5 V; 1-5 V	0-10 V	0.5-4.5 V	RS485 MODBUS
Power supply	10-30 V DC	10-30 V DC	10-30 V DC	5 V DC ± 5%	10-30 V DC
Life time	≥100,000,000 pressure cycles				
Electrical connection	Fixed cable and water proof IP68				
Filter	1. With a stainless steel filter, 2. With a nylon filter				
Response time	≤10ms				
Pressure type	Gauge pressure, absolute pressure optional				
Certificate	CE Certificate				
EMC standard	EN 61326-1:2013; EN 61326-2-3:2013 EN 61000-6-2:2005; EN61000-6-4:2007+A1				

Dimension and Drawing

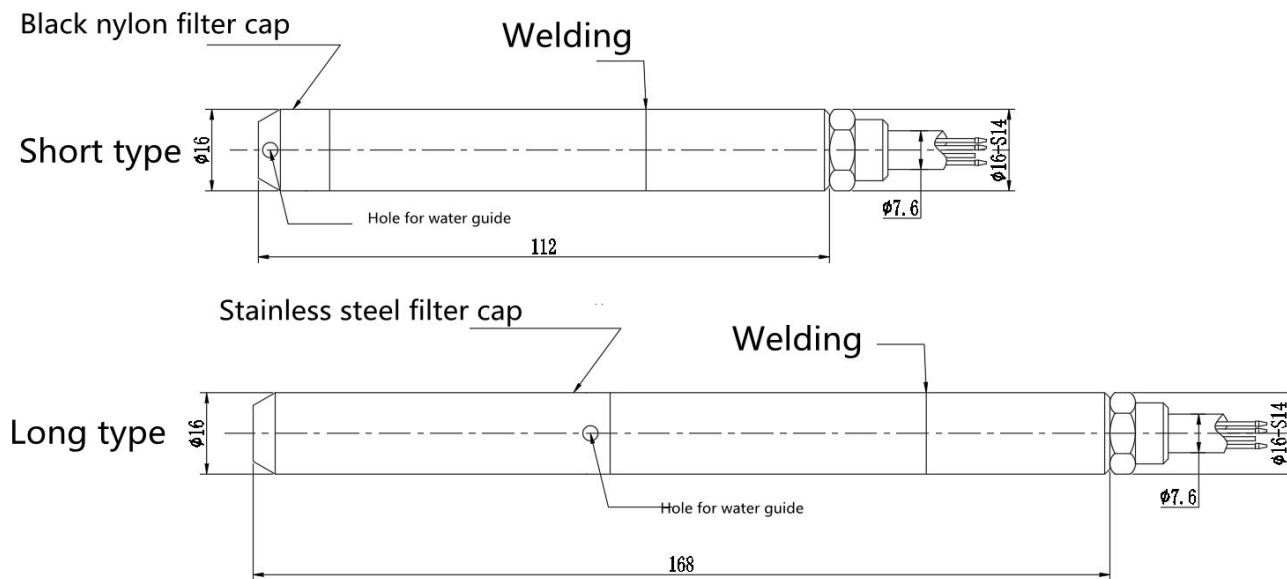

Electrical Connections

Electrical Connections

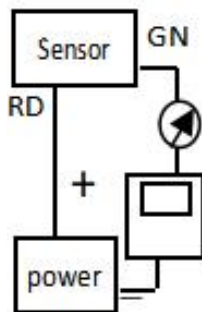

Current output, 2-wire

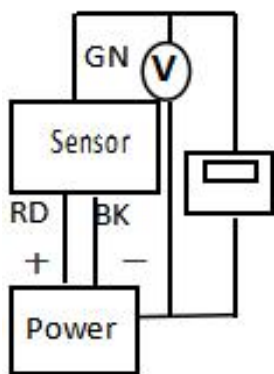

Voltage output, 3-wire

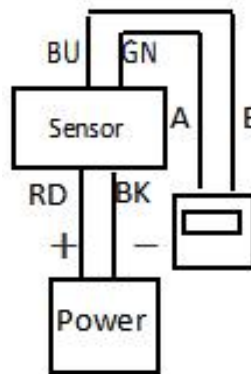

RS485 output

Part Number Code Table For Level Range

Unit: mH2O

020	0-20 mH2O	050	0-50 mH2O	120	0-120 mH2O
025	0-25 mH2O	060	0-60 mH2O	130	0-130 mH2O
030	0-30 mH2O	070	0-70 mH2O	150	0-150 mH2O
035	0-35 mH2O	080	0-80 mH2O	160	0-160 mH2O
040	0-40 mH2O	100	0-100 mH2O	200	0-200 mH2O
045	0-45 mH2O	110	0-110 mH2O	X	By customized

Unit: bar

02	0-2 bar G	08	0-8 bar G/A	14	0-14 bar G/A
03	0-3 bar G	09	0-9 bar G/A	15	0-15 bar G/A
04	0-4 bar G/A	10	0-10 bar G/A	16	0-16 bar G/A
05	0-5 bar G/A	11	0-11 bar G/A	18	0-18 bar G/A
06	0-6 bar G/A	12	0-12 bar G/A	20	0-20 bar G/A
07	0-7 bar G/A	13	0-13 bar G/A	X	By customized

